

VMAP USER MEETING 2026

**ENABLING DIGITAL CONTINUITY IN VIRTUAL
MANUFACTURING FOR ECO-EFFICIENCY ASSESSMENT OF
LIGHTWEIGHT STRUCTURES BY MEANS OF A DOMAIN-
SPECIFIC STRUCTURAL MECHANICS LANGUAGE**

Martin Rädels, Andreas Schuster, Felix Schoenitz, Jean Lefèvre

DLR, Institute of Lightweight Systems, Department Structural Mechanics & VPH

24.02.2026, St. Augustin, Germany

PredictECO

Gefördert durch:



Bundesministerium
für Forschung, Technologie
und Raumfahrt



2X10T

Imagine...



Full Scale
Static Test

Digital Design

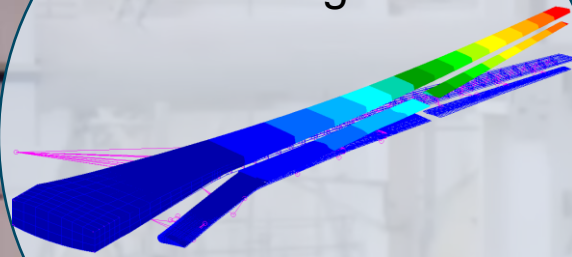

Virtual Testing

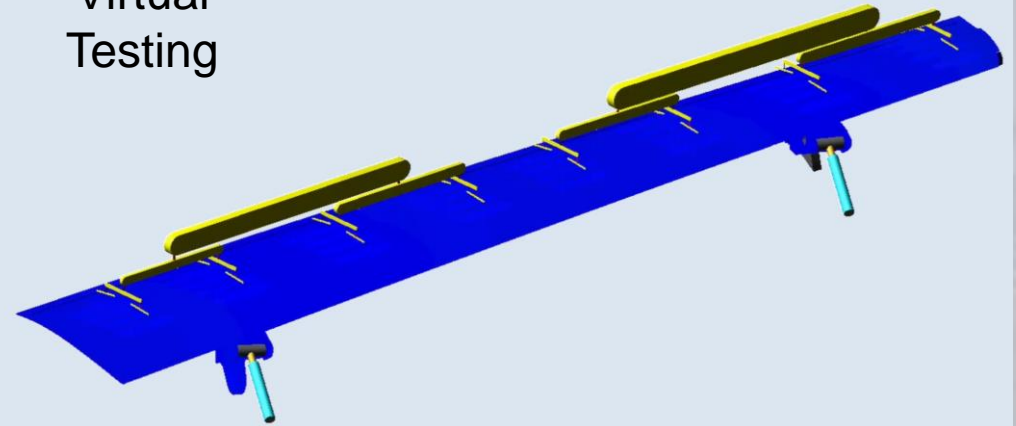

Virtual Manufacturing

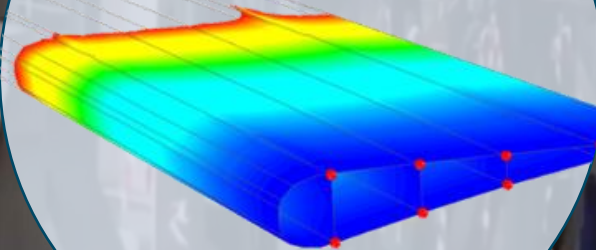

Applications:

- Virtual product development
- Eco-efficiency assessment

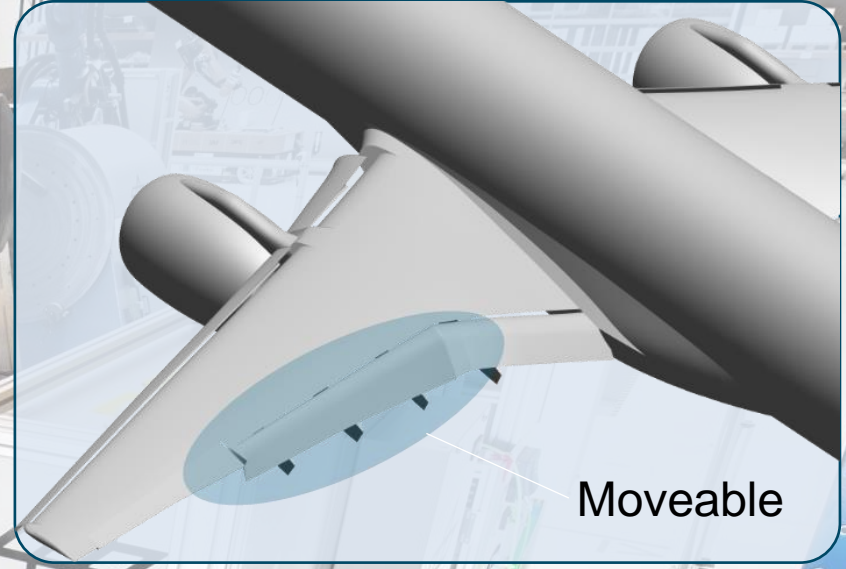
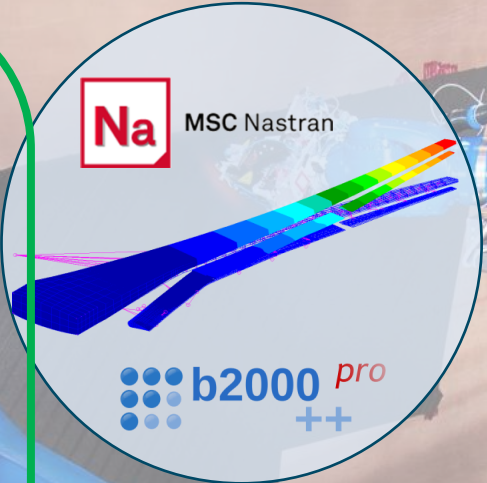
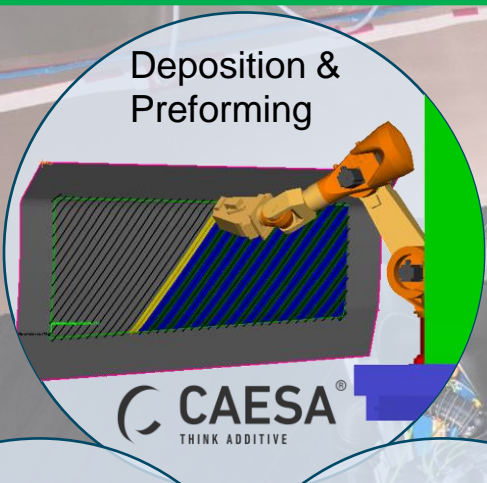

Moveable

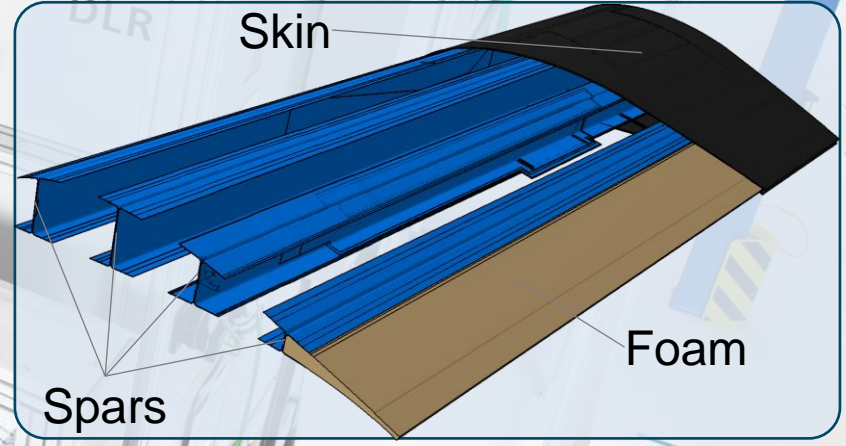
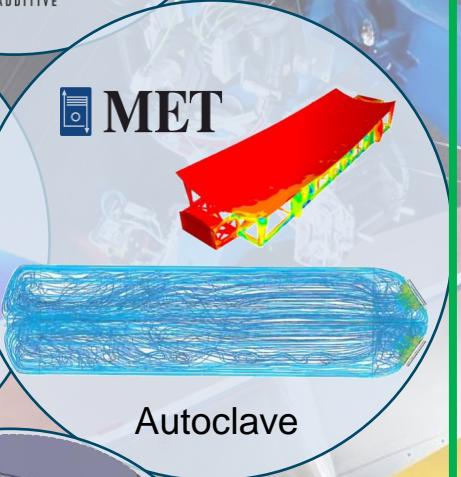
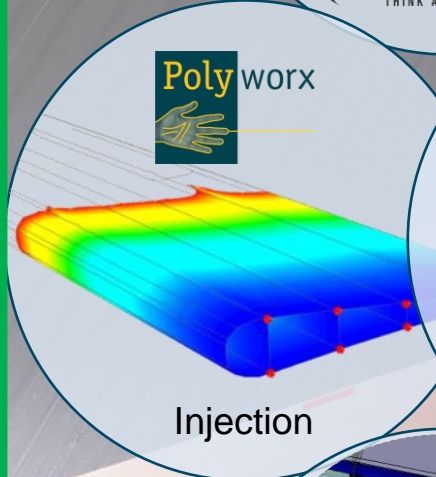

Skin

Spars

Foam

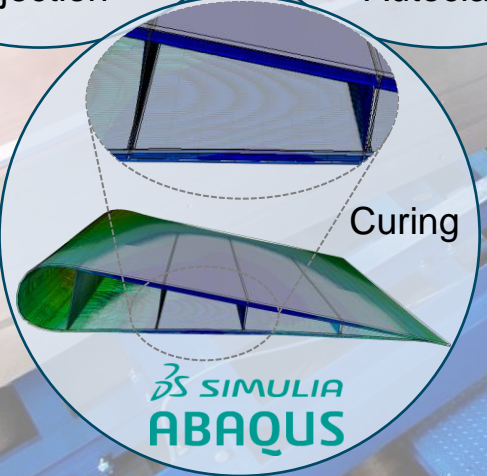

Curing

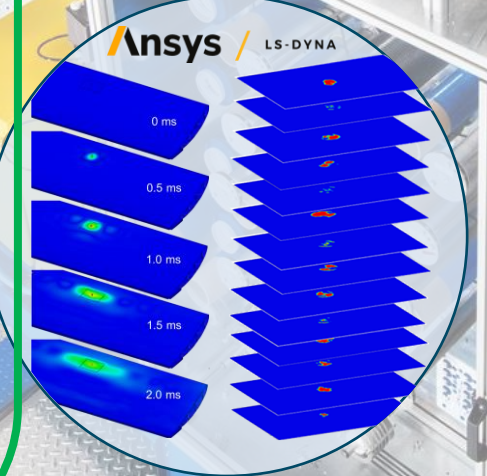

Ansys / LS-DYNA

0 ms

0.5 ms

1.0 ms

1.5 ms

2.0 ms



- Process with:
- Automation
 - Provenance
 - Feedback capabilities

Goal: Robustness

Manufacturing

Testing

Certification

Design

Digital continuity

Idea

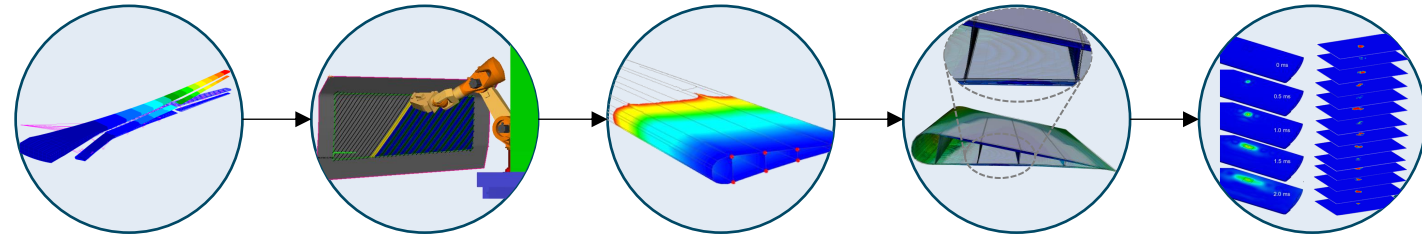

- End-to-end enabler:
 - common language
 - complete model & results

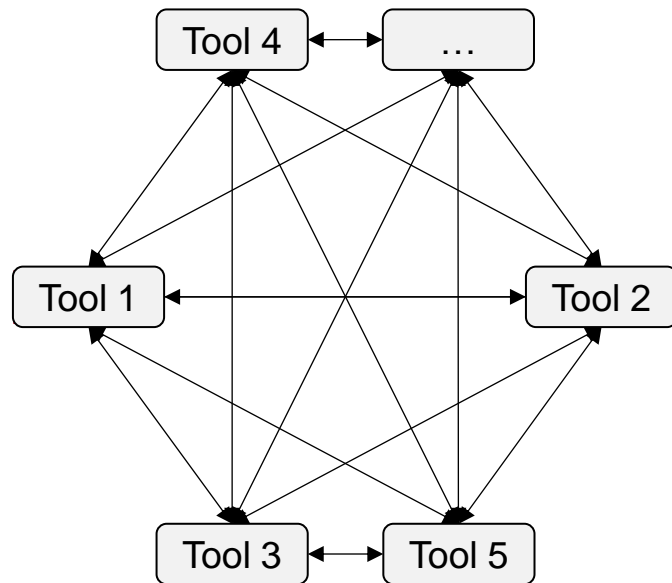

— Individual interfaces

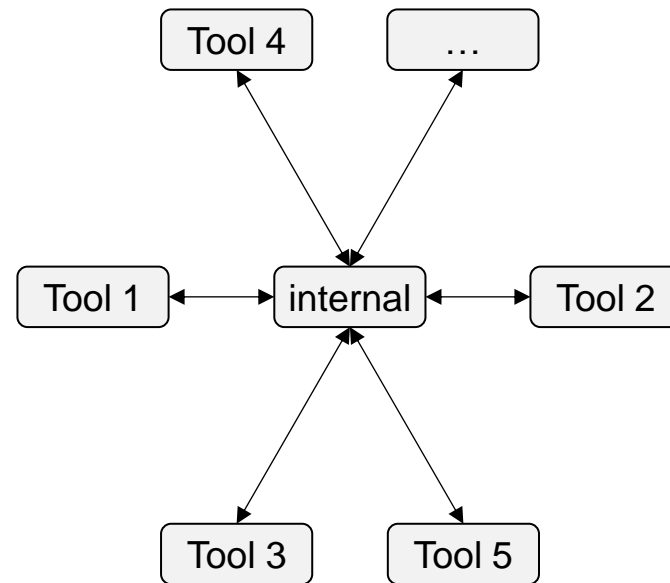

— Common data standard

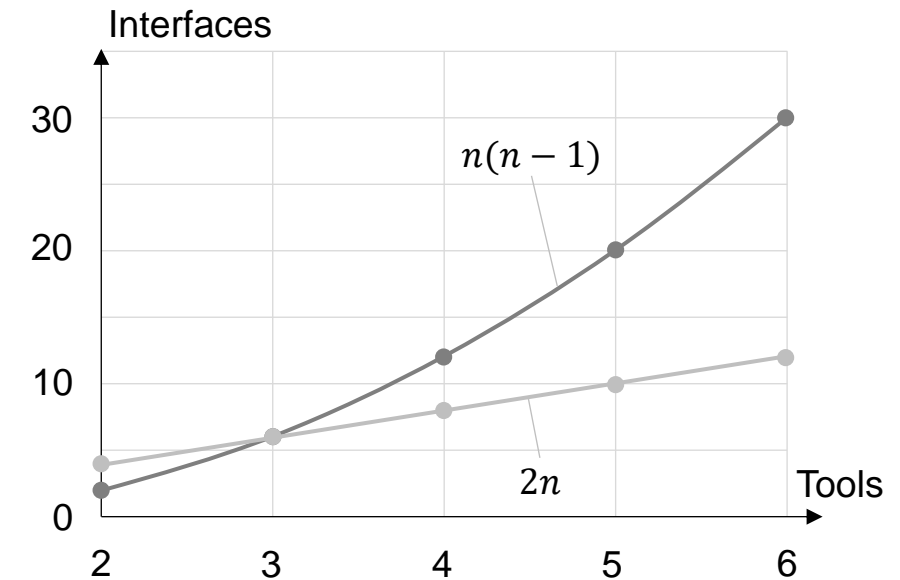

Digital continuity

Internal language

Subject to change in process

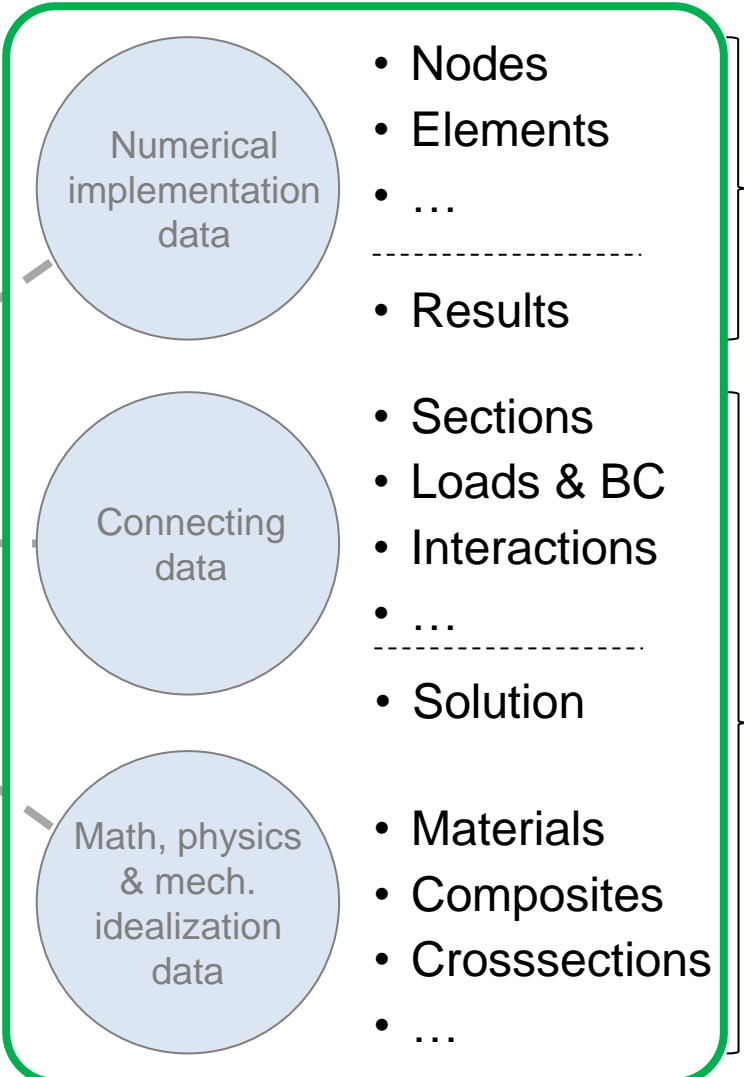
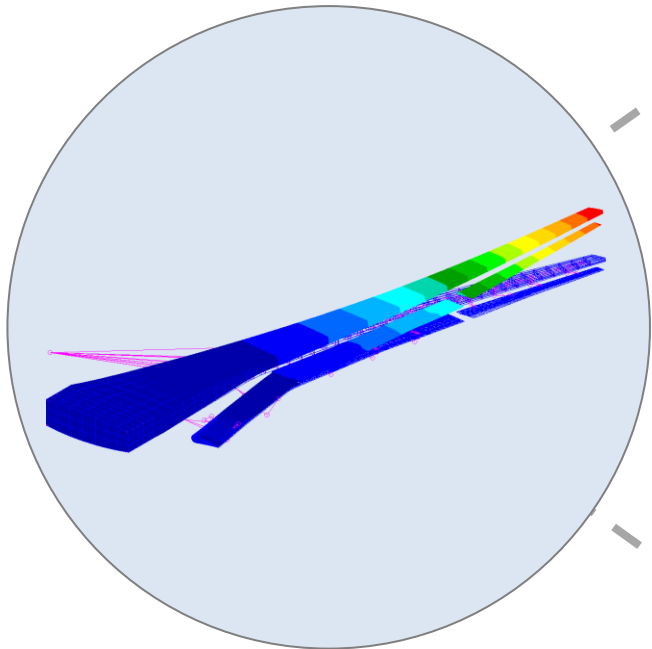

Define DTOs

DSL software packages

- Nodes
- Elements
- ...
- Results
- Sections
- Loads & BC
- Interactions
- ...
- Solution
- Materials
- Composites
- Crosssections
- ...

File representation

Heavy data



References

Light data

CoSMo

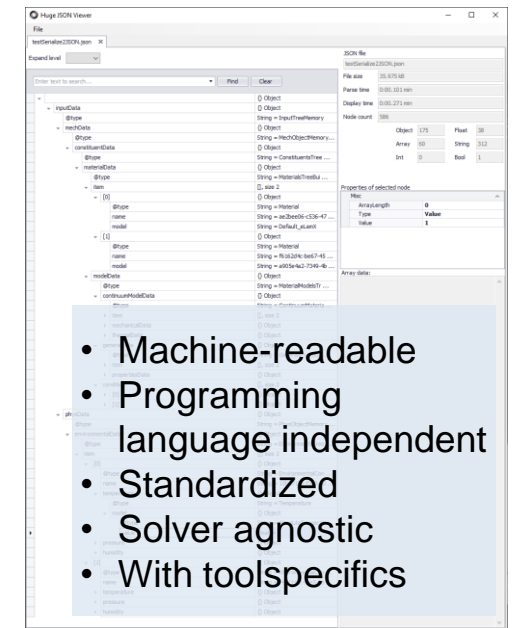
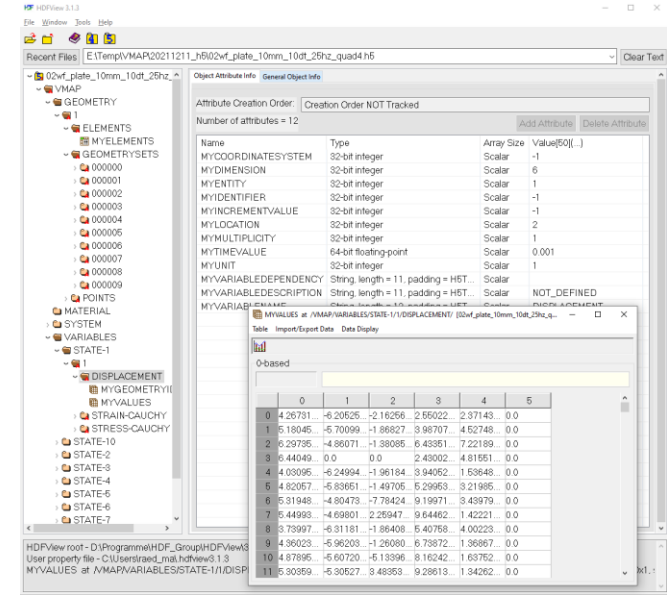

- Machine-readable
- Programming language independent
- Standardized
- Solver agnostic
- With toolspecifics

Digital continuity DSL

- Modular language vocabulary → based on level of assumptions & theories
- Reuse between levels

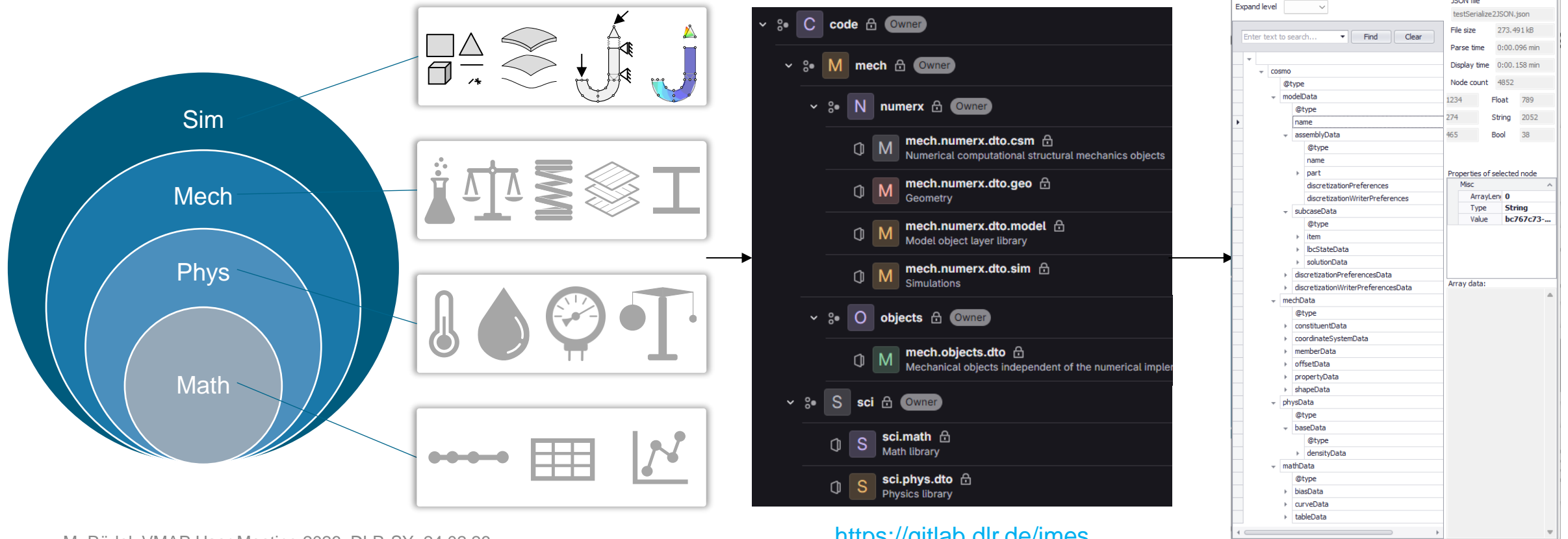

Digital continuity DSL



- Modular language vocabulary
- Reuse between levels

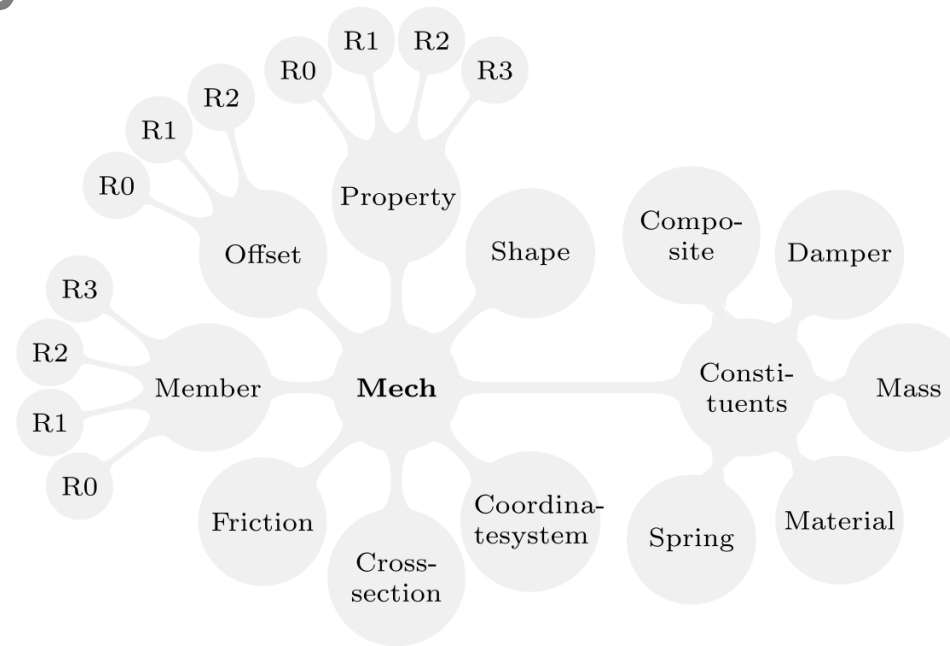

➔ Apps

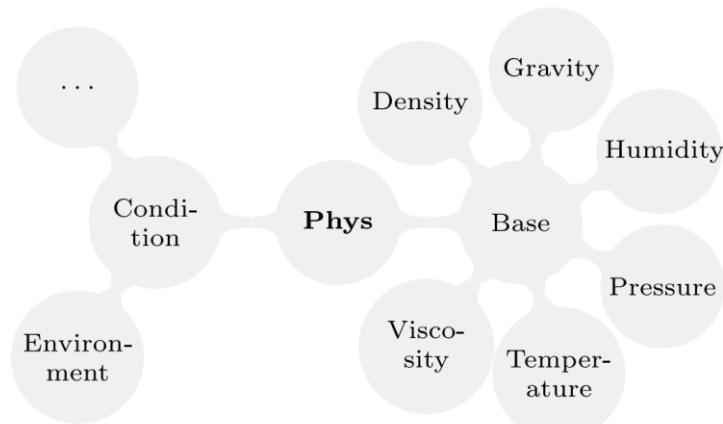
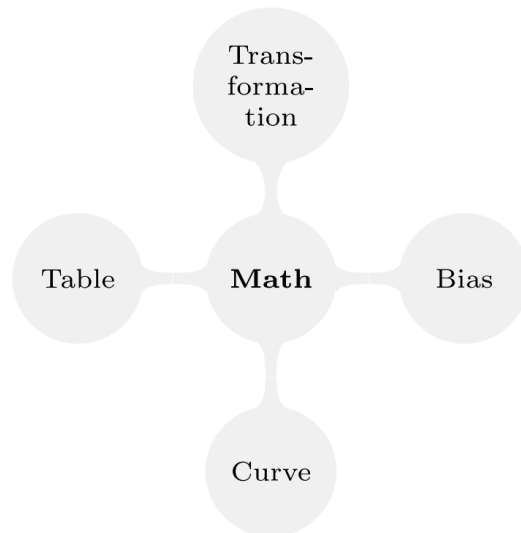
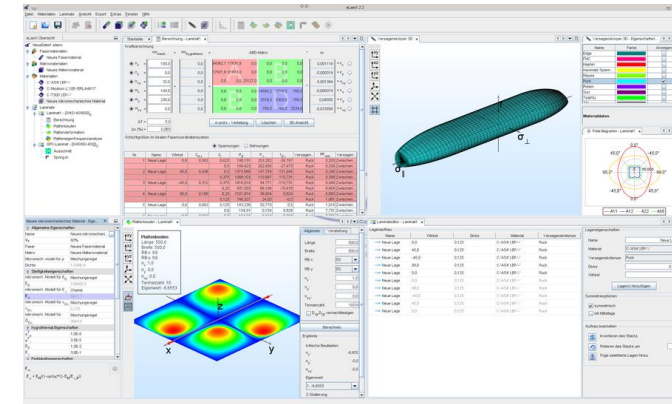

➔ Apps

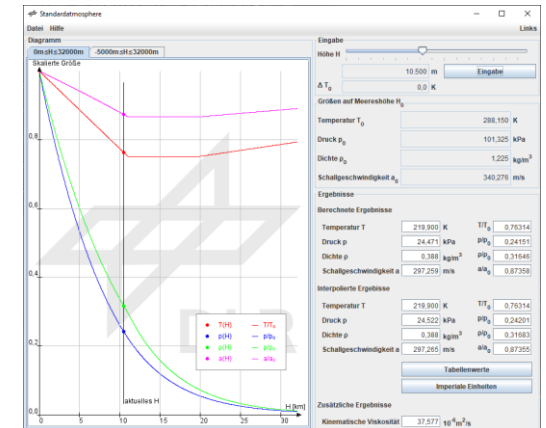

Digital continuity DSL



- Simplified from UML
- Based on user stories
- Expandable

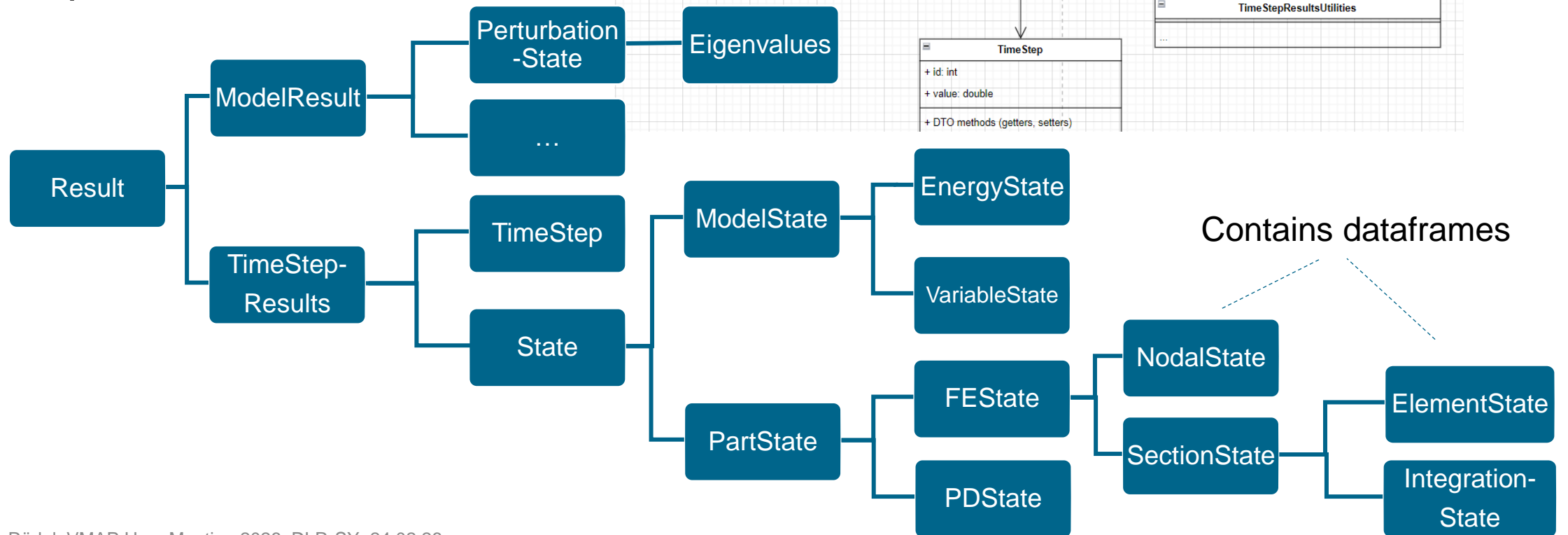
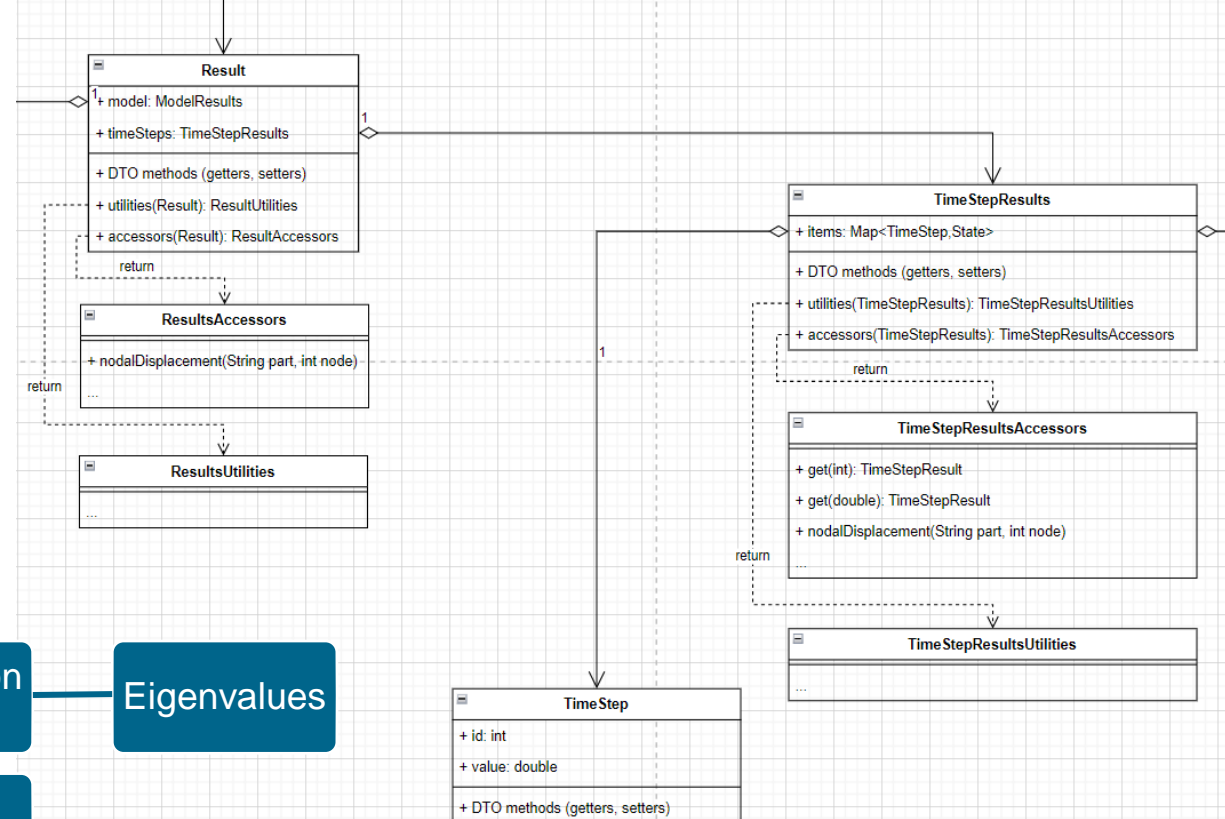

Digital continuity

Eco-system: Modeling & preprocessing



Conversion plugins

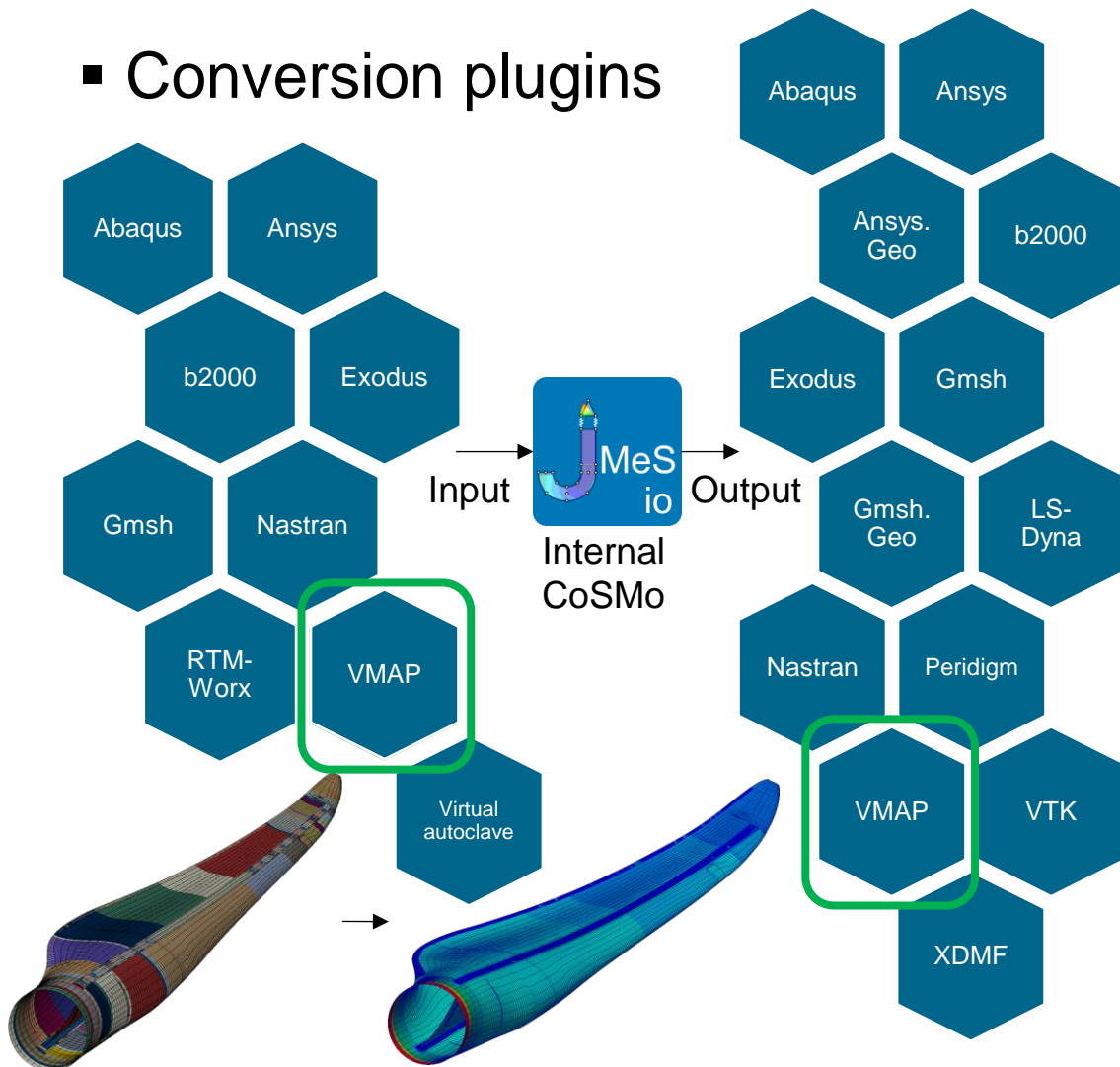

Idealization & theory-independent model generation

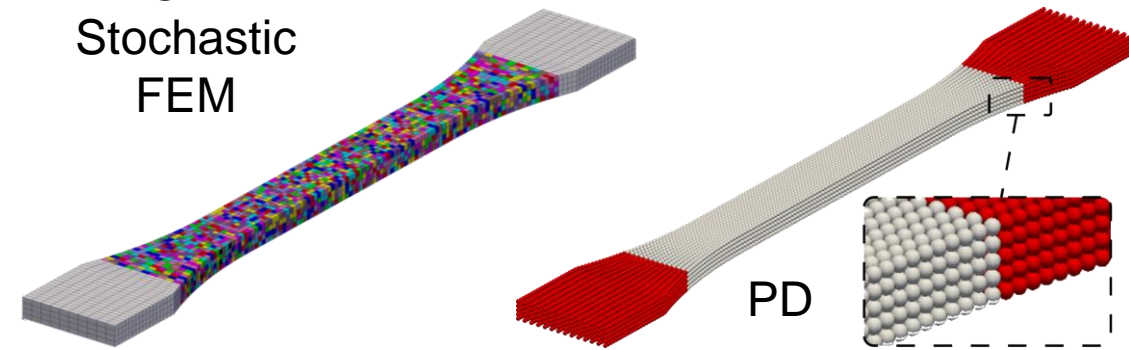

Probabilistic modeling & manipulation

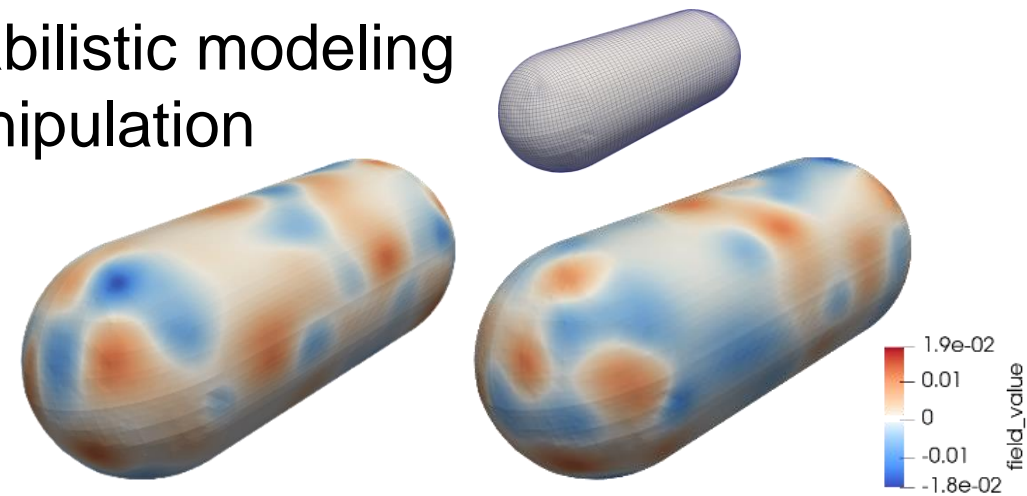

Mapping

Digital continuity

Eco-system: Postprocessing

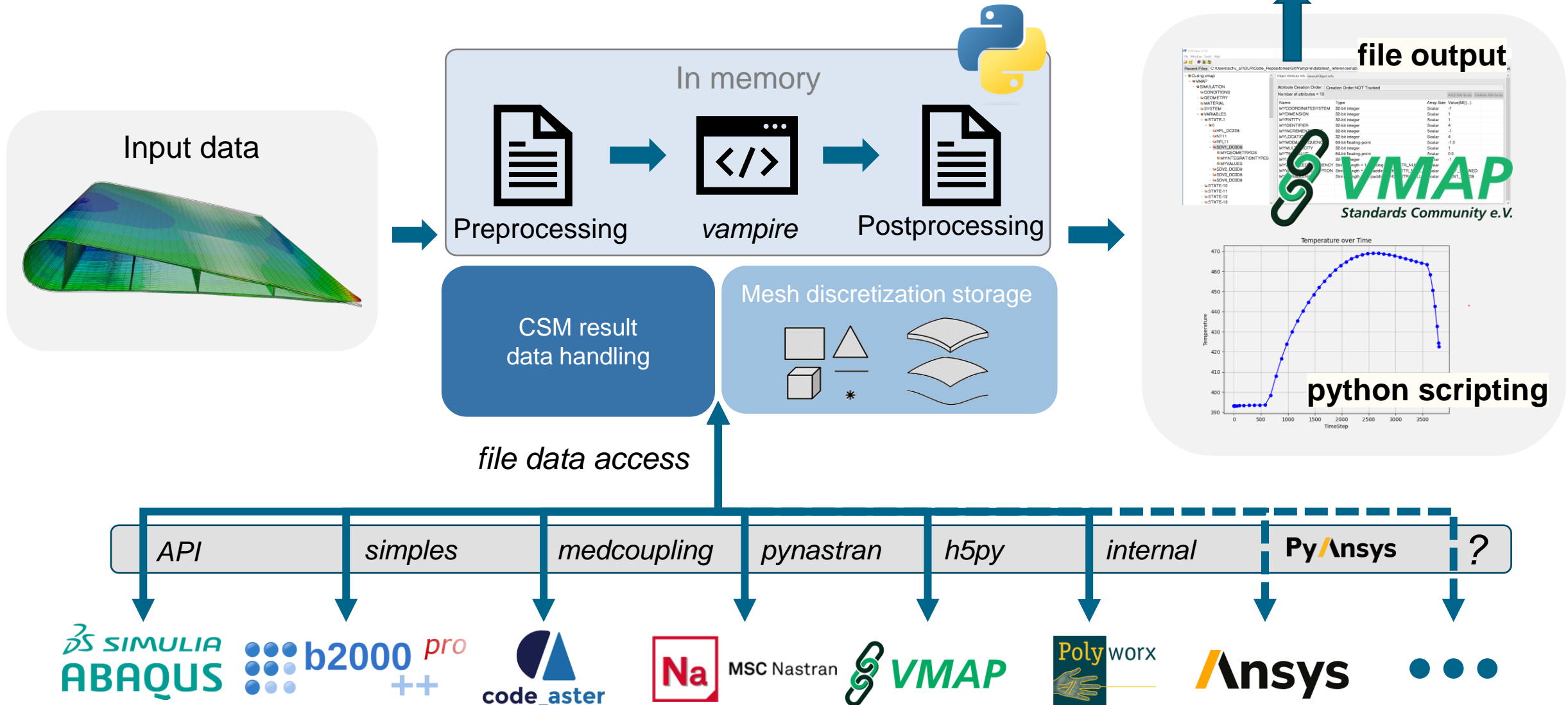

Applications

PredictECO

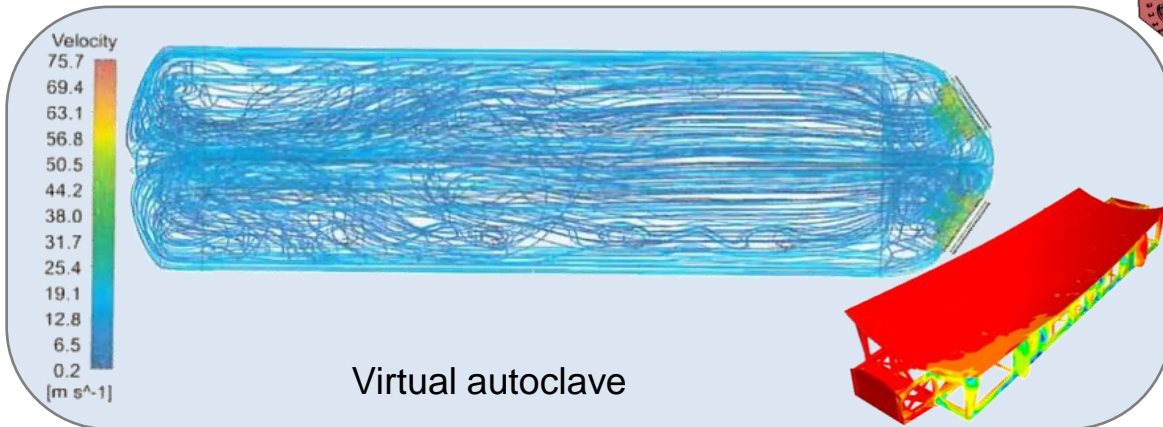
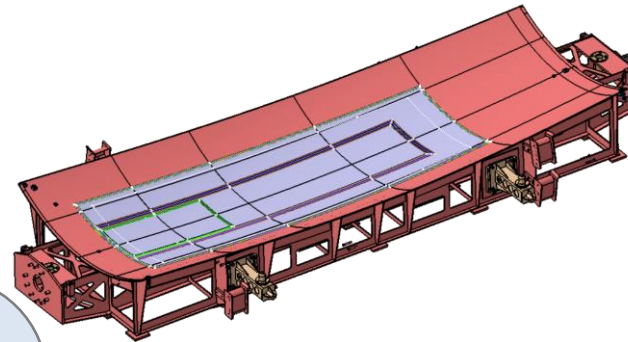
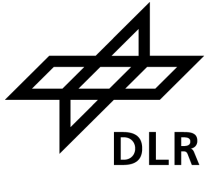

On specimen surface f(time):

Temperature
Heat transfer

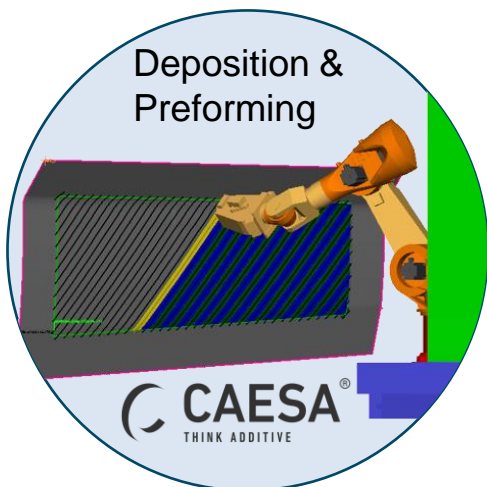
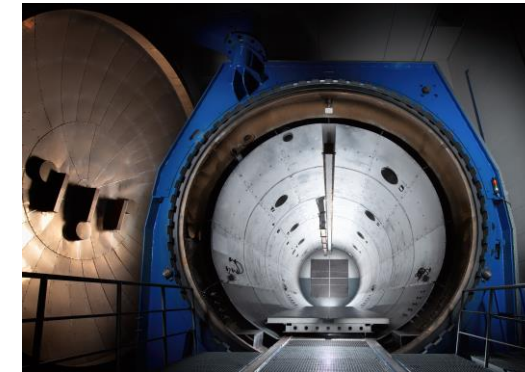

@ final state:
Gaps & overlaps

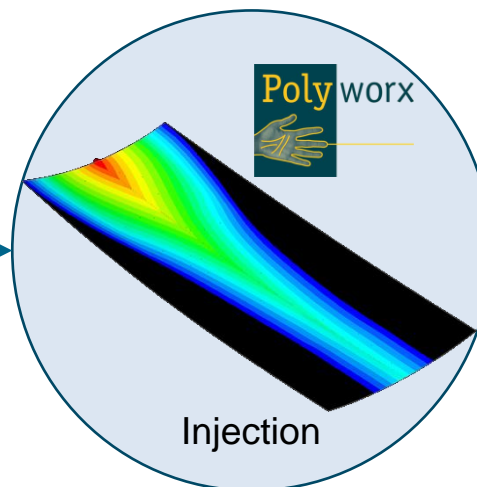

@ final state:
Fibre volume content
Degree of cure

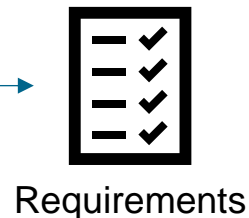
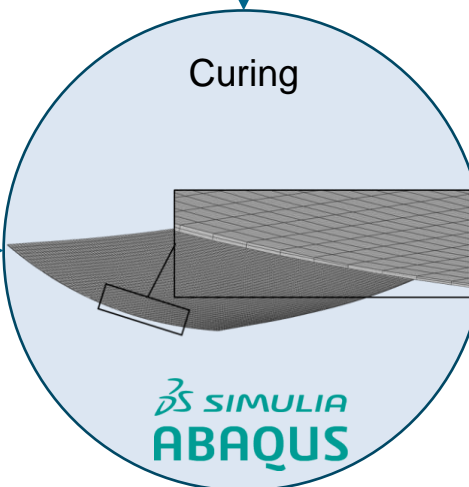

Material parameters, distributions, sections

Applications

PredictECO: Results

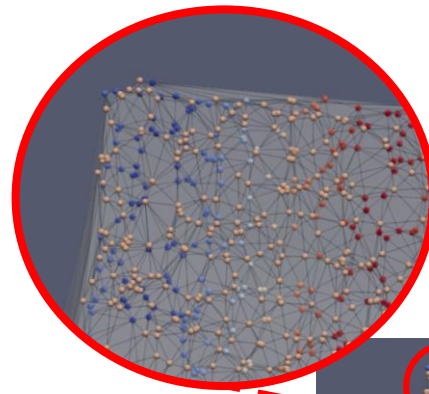
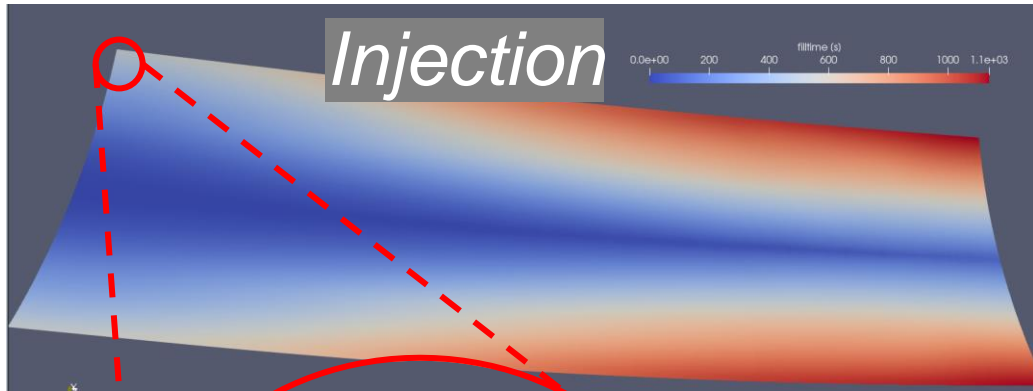

Point cloud data
Triangulation, Tetrahedralization

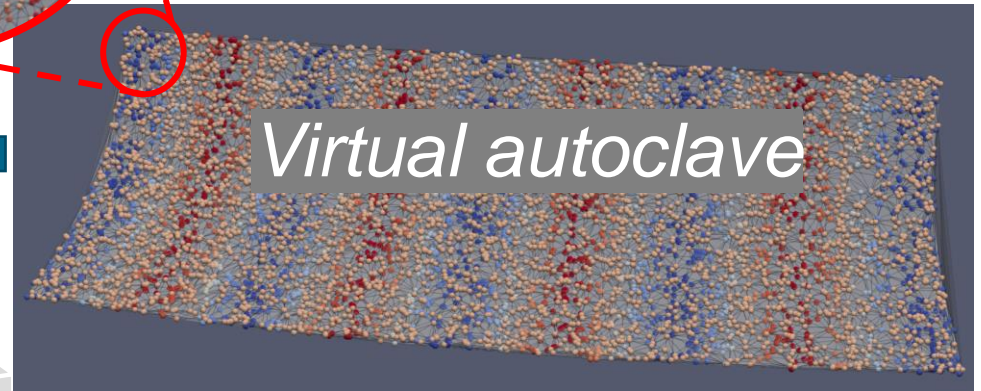

Virtual autoclave

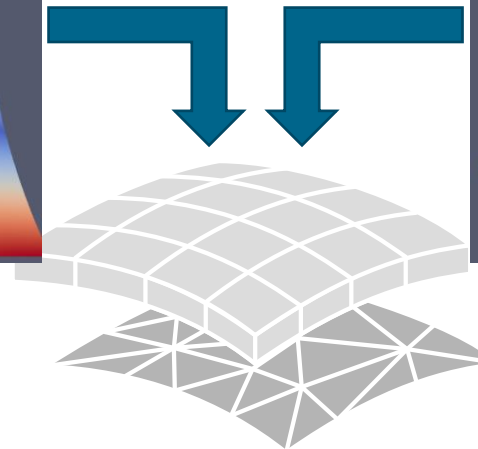

Mesh Interpolation

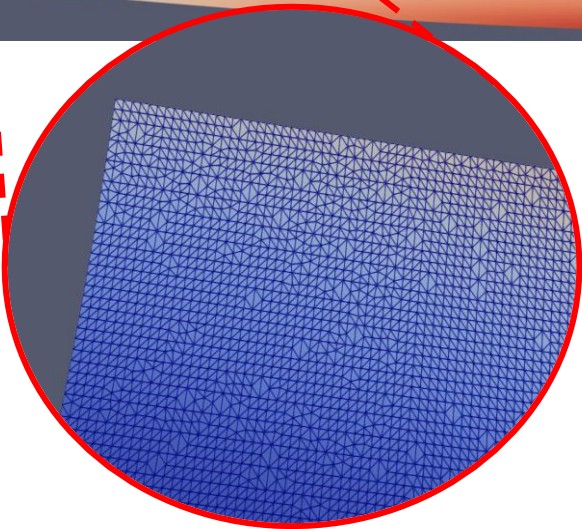

2.5D FEM/FVM

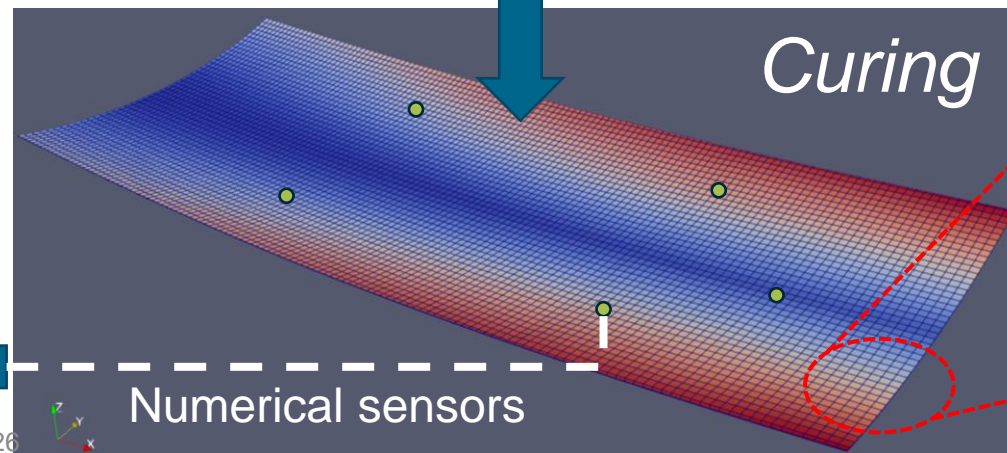

Curing

Numerical sensors

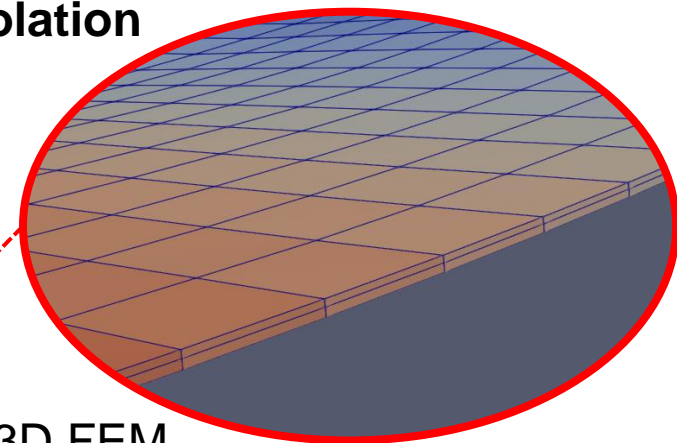

3D FEM

With proper through-thickness mapping



Conclusion & outlook



- VMAP is key ingredient in our processes
- Main applications:
 - Mapping
 - Visualization via ParaView
 - Storage via CoSMo (JSON + VMAP)
- Control over complete simulation (model + results) required
 - Approach presented
 - Functionality plugins; easily expandable
- Next steps:
 - Measurement data integration into virtual testing models (e.g. DIC)
 - Gladly exchange ideas about further developments together
 - Extend to query capabilities for model databases



THANK YOU FOR YOUR ATTENTION

Contact

Martin Rädels et al.

German Aerospace Center
Institute of Lightweight Systems
Department of Structural Mechanics

Lilienthalplatz 7
38108 Braunschweig

 +49 (0)531 295-2048

 +49 (0)531 295-2232

 martin.raedel@dlr.de

 www.dlr.de/sy

**PredictECO**

Virtual Product House

Cornelius-Edzard-Straße 15
28199 Bremen

Gefördert durch:



Bundesministerium
für Forschung, Technologie
und Raumfahrt



www.dlr.de/vph



Acknowledgement

Funding



- “PredictECO” - Produktentwicklung unter Berücksichtigung der simulationsgestützten Nachhaltigkeitsbewertung (grant number 01MN23014B) (06/2023 – 05/2026)

Gefördert durch:



Bundesministerium
für Forschung, Technologie
und Raumfahrt

Topic: **Enabling Digital Continuity in Virtual Manufacturing for Eco-Efficiency Assessment of Lightweight Structures by Means of a Domain-Specific Structural Mechanics Language**
VMAP User Form 2026

Date: 2026-02-24

Author: Martin Rädels, Andreas Schuster, Felix Schoenitz, Jean Lefèvre

Institute: DLR-SY

Image sources: All images “DLR (CC BY-NC-ND 3.0)” unless otherwise stated